

macchine edili ed agricole
d DIECI

Icarus 40.16

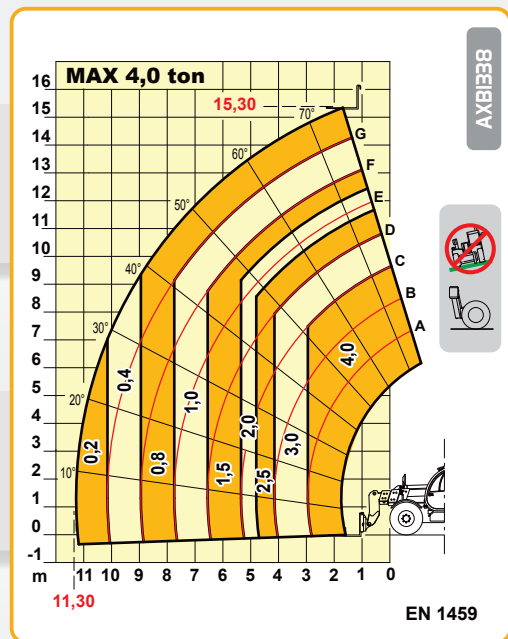

Icarus 40.16

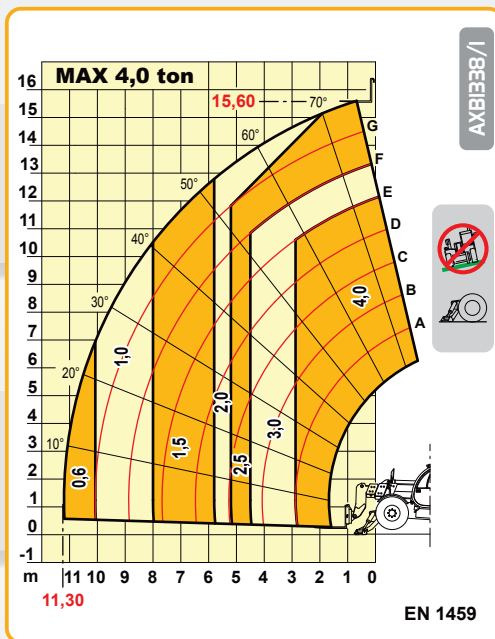
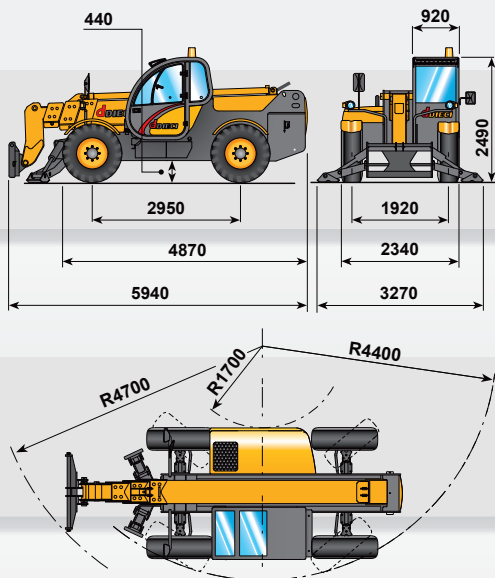

PERFORMANCES

Maximum capacity:..... 4.000 kg
 Capacity at maximum height on stabilizers:..... 2.500 kg
 Capacity at maximum height on tyres:..... 800 kg
 Capacity at maximum boom extension on stabilizers:..... 600 kg
 Capacity at maximum boom extension on tyres:..... 200 kg
 Maximum lifting height on stabilizers:..... 15,60 m
 Maximum lifting height on tyres:..... 15,30 m
 Maximum horizontal boom extension:..... 11,30 m
 Boom extension at maximum height:..... 1,70 m
 Fork tilting angle:..... 134°
 Tearing force:..... 5.700 daN
 Towing force:..... 7.300 daN
 Maximum allowable slope:..... 40 %
 Total empty weight:..... 12.000 kg
 Max speed:..... 30 km/h
 (on request 40 km/h with TA engine)



TRANSMISSION

Transmission:..... hydrostatic with variable delivery pump
 Hydraulic engine:..... with automatic adjustment
 Reversing gear:..... electro - hydraulic
 Inching pedal for controlled forward movement.
 Servocontrolled 2 speed gearbox.



HYDRAULIC SYSTEM

Gear pump with capacity at max speed:..... 100 lt/1'
 Max working pressure:..... 230 bar
 Control valve with joystick:..... 3 in 1



DIFFERENTIAL AXLES

Steering axles:..... 2, with planetary reduction gears
 Type of steering:..... 4 wheels / transversal / 2 wheels
 Front axle:..... rigid (levelling on request)
 Rear axle:..... oscillating
 Service brake:..oil bath on the 4 wheels with double hydraulic system and servo-brake

Negative parking brake



ENGINE

IVECO NEF - TA - 74 kW ENGINE

Maximum power:..... 74 kW (101 hp) at 2200 rpm
 Operating principle:..... four-stroke, diesel engine
 Cylinder number and layout:..... 4, vertical in line
 Displacement:..... 4485 cm³ - Aftercooler turbo compressor
 Cooling system:..... liquid

IVECO NEF - TA - 93 kW ENGINE

Maximum net power:..... 93 kW (127 HP) at 2200 rpm
 Operating principle:..... four-stroke, diesel engine
 Number of cylinders and layout:..... 4, vertical in line
 Displacement:..... 4485 cm³ - Aftercooler turbo compressor
 Cooling system:..... liquid



REFUELLING (litre)

Hydraulic tank:..... 160
 Fuel tank:..... 105



STANDARD DEVICES

Anti-tipping device with block for hazardous movements.
 Hydraulic socket for possible accessories on boom head.
 Closed soundproof ROPS - FOPS approved driver's cab, with heating.
 Self-locking differential on front axle (limited slip 45%).
 Stabilizers with independent hydraulic tilting.



TYRES

Tyres:..... 405/70x24"



OPTIONAL AND ACCESSORIES

Optional and Accessories:..... see the relevant catalogue

The information contained in this publication is merely indicative; the models described may be modified, without notice, by the manufacturer, drawings and photographs may refer to optional or particular equipment for other countries. For any further information, please contact DIECI premises at the address given below.